



Intel® Cyclone® 10 GX Native Fixed Point DSP IP Core User Guide



Contents

1 Intel® Cyclone® 10 GX Native Fixed Point DSP IP Core User Guide.....	3
1.1 Cyclone 10 GX Native Fixed Point DSP IP Core Features.....	4
2 Getting Started.....	5
2.1 Cyclone 10 GX Native Fixed Point DSP IP Core Parameter Settings.....	5
2.1.1 Operation Mode Tab.....	5
2.1.2 Pre-adder Tab.....	9
2.1.3 Internal Coefficient Tab.....	9
2.1.4 Accumulator/Output Cascade Tab.....	10
2.1.5 Pipelining Tab.....	12
2.1.6 Maximum Input Data Width Per Operation Mode.....	12
3 Functional Description.....	14
3.1 Operational Modes.....	14
3.1.1 The 18 × 18 Full Mode.....	14
3.1.2 The 18 × 18 Sum of 2 Mode.....	15
3.1.3 The 18 × 18 Plus 36 Mode.....	16
3.1.4 The 18 × 18 Systolic Mode.....	18
3.1.5 The 27 × 27 Mode.....	18
3.2 Optional Modules.....	19
3.2.1 Input Cascade.....	19
3.2.2 Pre-adder.....	20
3.2.3 Internal Coefficient.....	20
3.2.4 Accumulator and Output Cascade.....	20
3.2.5 Pipeline Register.....	21
3.3 Clocking Scheme.....	21
3.4 Cyclone 10 GX Native Fixed Point DSP IP Core Signals.....	22
A Document Revision History for the Cyclone 10 GX Native Fixed Point DSP IP Core User Guide.....	26



1 Intel® Cyclone® 10 GX Native Fixed Point DSP IP Core User Guide

The Intel Cyclone® 10 GX Native Fixed Point DSP IP core instantiates and controls a single Intel Cyclone 10 GX Variable Precision Digital Signal Processing (DSP) block. The Cyclone 10 GX Native Fixed Point DSP IP core is only available for Intel Cyclone 10 GX devices.

Figure 1. Cyclone 10 GX Native Fixed Point DSP IP Core Functional Block Diagram

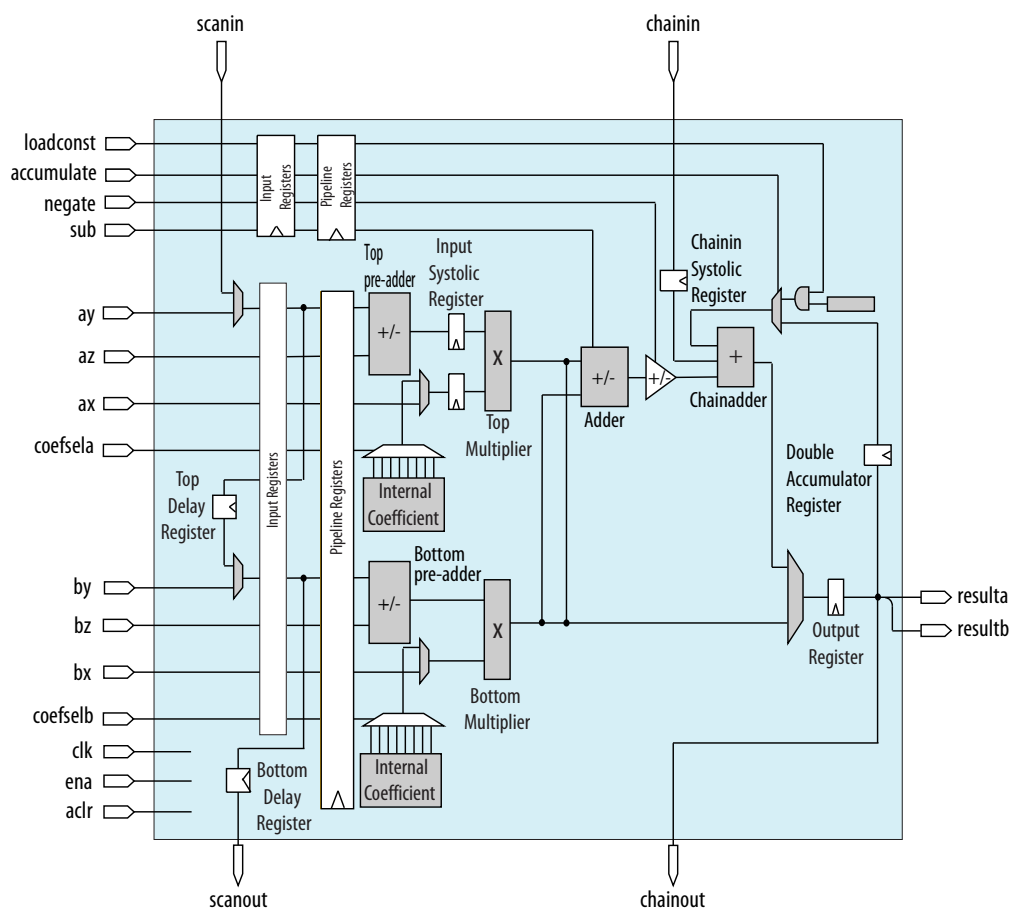

Related Links

[Introduction to Intel FPGA IP Cores](#)

Intel Corporation. All rights reserved. Intel, the Intel logo, Altera, Arria, Cyclone, Enpirion, MAX, Nios, Quartus and Stratix words and logos are trademarks of Intel Corporation or its subsidiaries in the U.S. and/or other countries. Intel warrants performance of its FPGA and semiconductor products to current specifications in accordance with Intel's standard warranty, but reserves the right to make changes to any products and services at any time without notice. Intel assumes no responsibility or liability arising out of the application or use of any information, product, or service described herein except as expressly agreed to in writing by Intel. Intel customers are advised to obtain the latest version of device specifications before relying on any published information and before placing orders for products or services.

*Other names and brands may be claimed as the property of others.

ISO
9001:2008
Registered



1.1 Cyclone 10 GX Native Fixed Point DSP IP Core Features

The Cyclone 10 GX Native Fixed Point DSP IP core supports the following features:

- High-performance, power-optimized, and fully registered multiplication operations
- 18-bit and 27-bit word lengths
- Two 18×19 multipliers or one 27×27 multiplier per DSP block
- Built-in addition, subtraction, and 64-bit double accumulation register to combine multiplication results
- Cascading 19-bit or 27-bit when pre-adder is disabled and cascading 18-bit when pre-adder is used to form the tap-delay line for filtering applications
- Cascading 64-bit output bus to propagate output results from one block to the next block without external logic support
- Hard pre-adder supported in 19-bit and 27-bit modes for symmetric filters
- Internal coefficient register bank in both 18-bit and 27-bit modes for filter implementation
- 18-bit and 27-bit systolic finite impulse response (FIR) filters with distributed output adder



2 Getting Started

This chapter provides a general overview of the Intel FPGA IP core design flow to help you quickly get started with the Cyclone 10 GX Native Fixed Point DSP IP core. The Intel FPGA IP Library is installed as part of the Intel Quartus® Prime installation process. You can select and parameterize any Intel FPGA IP core from the library. Intel provides an integrated parameter editor that allows you to customize the Intel FPGA DSP IP core to support a wide variety of applications. The parameter editor guides you through the setting of parameter values and selection of optional ports.

Related Links

- [Introduction to Intel FPGA IP Cores](#)
Provides general information about all Intel FPGA IP cores, including parameterizing, generating, upgrading, and simulating IP cores.
- [Creating Version-Independent IP and Platform Designer \(Standard\) Simulation Scripts](#)
Create simulation scripts that do not require manual updates for software or IP version upgrades.
- [Project Management Best Practices](#)
Guidelines for efficient management and portability of your project and IP files.

2.1 Cyclone 10 GX Native Fixed Point DSP IP Core Parameter Settings

You can customize the Cyclone 10 GX Native Fixed Point DSP IP core by specifying the parameters using the parameter editor in the Intel Quartus Prime software.

2.1.1 Operation Mode Tab

Table 1. Operation Mode Tab

Parameter	IP Generated Parameter	Value	Description
Please choose the operation mode	operation_mode	m18x18_full m18x18_sumof2 m18x18_plus36 m18x18_systolic m27x27	Select the desired operational mode.
Multiplier Configuration			
Representation format for top multiplier x operand	signed_max	signed unsigned	Specify the representation format for the top multiplier x operand.
<i>continued...</i>			

Intel Corporation. All rights reserved. Intel, the Intel logo, Altera, Arria, Cyclone, Enpirion, MAX, Nios, Quartus and Stratix words and logos are trademarks of Intel Corporation or its subsidiaries in the U.S. and/or other countries. Intel warrants performance of its FPGA and semiconductor products to current specifications in accordance with Intel's standard warranty, but reserves the right to make changes to any products and services at any time without notice. Intel assumes no responsibility or liability arising out of the application or use of any information, product, or service described herein except as expressly agreed to in writing by Intel. Intel customers are advised to obtain the latest version of device specifications before relying on any published information and before placing orders for products or services.

*Other names and brands may be claimed as the property of others.

ISO
9001:2008
Registered



Parameter	IP Generated Parameter	Value	Description
Representation format for top multiplier y operand	signed_may	signed unsigned	Specify the representation format for the top multiplier y operand.
Representation format for bottom multiplier x operand	signed_mbx	signed unsigned	Specify the representation format for the bottom multiplier x operand.
Representation format for bottom multiplier y operand	signed_mby	signed unsigned	Specify the representation format for the bottom multiplier y operand. Always select unsigned for m18x18_plus36 .
Enable 'sub' port	enable_sub	No Yes	Select Yes to enable sub port.
Register input 'sub' of the multiplier	sub_clock	No Clock0 Clock1 Clock2	Select Clock0 , Clock1 , or Clock2 to enable and specify the input clock signal for sub input register.
Input Cascade			
Enable input cascade for 'ay' input	ay_use_scan_in	No Yes	Select Yes to enable input cascade module for ay data input. When you enable input cascade module, the Cyclone 10 GX Native Fixed Point DSP IP core uses the scanin input signals as input instead of ay input signals.
Enable input cascade for 'by' input	by_use_scan_in	No Yes	Select Yes to enable input cascade module for by data input. When you enable input cascade module, the Cyclone 10 GX Native Fixed Point DSP IP core uses the ay input signals as input instead of by input signals.
Enable data ay delay register	delay_scan_out_ay	No Yes	Select Yes to enable delay register between ay and by input registers. This feature is not supported in m18x18_plus36 and m27x27 operational mode.
continued...			



Parameter	IP Generated Parameter	Value	Description
Enable data by delay register	delay_scan_out_by	No Yes	Select Yes to enable delay register between by input registers and scanout output bus. This feature is not supported in m18x18_plus36 and m27x27 operational mode.
Enable scanout port	gui_scanout_enable	No Yes	Select Yes to enable scanout output bus.
'scanout' output bus width	scan_out_width	1-27	Specify the width of scanout output bus.
Data 'x' Configuration			
'ax' input bus width	ax_width	1-27	Specify the width of ax input bus. ⁽¹⁾
Register input 'ax' of the multiplier	ax_clock	No Clock0 Clock1 Clock2	Select Clock0 , Clock1 , or Clock2 to enable and specify the input clock signal for ax input register. ax input register is not available if you set 'ax' operand source to 'coef' .
'bx' input bus width	bx_width	1-18	Specify the width of bx input bus. ⁽¹⁾
Register input 'bx' of the multiplier	bx_clock	No Clock0 Clock1 Clock2	Select Clock0 , Clock1 , or Clock2 to enable and specify the input clock signal for bx input register. bx input register is not available if you set 'bx' operand source to 'coef' .
Data 'y' Configuration			
'ay' or 'scanin' bus width	ay_scan_in_width	1-27	Specify the width of ay or scanin input bus. ⁽¹⁾
Register input 'ay' or input 'scanin' of the multiplier	ay_scan_in_clock	No Clock0 Clock1 Clock2	Select Clock0 , Clock1 , or Clock2 to enable and specify the input clock signal for ay or scanin input register.
'by' input bus width	by_width	1-19	Specify the width of by input bus. ⁽¹⁾
continued...			

(1) Refer to [Maximum Input Data Width Per Operation Mode](#) on page 12



Parameter	IP Generated Parameter	Value	Description
Register input 'by' of the multiplier	by_clock	No Clock0 Clock1 Clock2	Select Clock0 , Clock1 , or Clock2 to enable and specify the input clock signal for by or scanin input register. ⁽¹⁾
Output 'result' Configuration			
'resulta' output bus width	result_a_width	1-64	Specify the width of resulta output bus.
'resultb' output bus width	result_b_width	1-64	Specify the width of resultb output bus. resultb only available when using operation_mode m18x18_full .
Use output register	output_clock	No Clock0 Clock1 Clock2	Select Clock0 , Clock1 , or Clock2 to enable and specify the input clock signal for resulta and resultb output registers.



2.1.2 Pre-adder Tab

Table 2. Pre-adder Tab

Parameter	IP Generated Parameter	Value	Description
'ay' operand source	operand_source_may	input preadder	Specify the operand source for ay input. Select preadder to enable pre-adder module for top multiplier. Settings for ay and by operand source must be the same.
'by' operand source	operand_source_mby	input preadder	Specify the operand source for by input. Select preadder to enable pre-adder module for bottom multiplier. Settings for ay and by operand source must be the same.
Set pre-adder a operation to subtraction	preadder_subtract_a	No Yes	Select Yes to specify subtraction operation for pre-adder module for the top multiplier. Pre-adder settings for top and bottom multiplier must be the same.
Set pre-adder b operation to subtraction	preadder_subtract_b	No Yes	Select Yes to specify subtraction operation for pre-adder module for the bottom multiplier. Pre-adder settings for top and bottom multiplier must be the same.
Data 'z' Configuration			
'az' input bus width	az_width	1-26	Specify the width of az input bus. ⁽¹⁾
Register input 'az' of the multiplier	az_clock	No Clock0 Clock1 Clock2	Select Clock0 , Clock1 , or Clock2 to enable and specify the input clock signal for az input registers. Clock settings for ay and az input registers must be the same.
'bz' input bus width	bz_width	1-18	Specify the width of bz input bus. ⁽¹⁾
Register input 'bz' of the multiplier	bz_clock	No Clock0 Clock1 Clock2	Select Clock0 , Clock1 , or Clock2 to enable and specify the input clock signal for bz input registers. Clock settings for by and bz input registers must be the same.

2.1.3 Internal Coefficient Tab

Table 3. Internal Coefficient Tab

Parameter	IP Generated Parameter	Value	Description
'ax' operand source	operand_source_max	input coef	Specify the operand source for ax input bus. Select coef to enable internal coefficient module for top multiplier. Select No for Register input 'ax' of the multiplier parameter when you enable the internal coefficient feature.

continued...



Parameter	IP Generated Parameter	Value	Description
			Settings for <i>ax</i> and <i>bx</i> operand source must be the same.
' <i>bx</i> ' operand source	operand_source_mbx	input coef	Specify the operand source for <i>bx</i> input bus. Select coef to enable internal coefficient module for top multiplier. Select No for Register input '<i>bx</i>' of the multiplier parameter when you enable the internal coefficient feature. Settings for <i>ax</i> and <i>bx</i> operand source must be the same.
'coefsel' Input Register Configuration			
Register input ' <i>coef</i> sela' of the multiplier	coef_sel_a_clock	No Clock0 Clock1 Clock2	Select Clock0 , Clock1 , or Clock2 to enable and specify the input clock signal for the <i>coef</i> sela input registers.
Register input ' <i>coef</i> selb' of the multiplier	coef_sel_b_clock	No Clock0 Clock1 Clock2	Select Clock0 , Clock1 , or Clock2 to enable and specify the input clock signal for the <i>coef</i> selb input registers.
Coefficient Storage Configuration			
coef_a_0-7	coef_a_0-7	Integer	Specify the coefficient values for <i>ax</i> input bus. For 18-bit operation mode, the maximum input value is $2^{18} - 1$. For 27-bit operation, the maximum value is $2^{27} - 1$.
coef_b_0-7	coef_b_0-7	Integer	Specify the coefficient values for <i>bx</i> input bus.

2.1.4 Accumulator/Output Cascade Tab

Table 4. Accumulator/Output Cascade Tab

Parameter	IP Generated Parameter	Value	Description
Enable 'accumulate' port	enable_accumulate	No Yes	Select Yes to enable accumulator port.
Enable 'negate' port	enable_negate	No Yes	Select Yes to enable negate port.
Enable 'loadconst' port	enable_loadconst	No Yes	Select Yes to enable loadconst port.
Register input 'accumulate' of the accumulator	accumulate_clock	No Clock0 Clock1 Clock2	Select Clock0 , Clock1 , or Clock2 to enable and specify the input clock signal for the accumulate input registers.
<i>continued...</i>			



Parameter	IP Generated Parameter	Value	Description
Register input 'loadconst' of the accumulator	load_const_clock	No Clock0 Clock1 Clock2	Select Clock0 , Clock1 , or Clock2 to enable and specify the input clock signal for the loadconst input registers.
Register input 'negate' of the adder unit	negate_clock	No Clock0 Clock1 Clock2	Select Clock0 , Clock1 , or Clock2 to enable and specify the input clock signal for the negate input registers.
Enable double accumulator	enable_double_accum	No Yes	Select Yes to enable double accumulator feature.
N value of preset constant	load_const_value	0 – 63	Specify the preset constant value. This value can be 2^N where N is the preset constant value.
Enable chainin port	use_chainadder	No Yes	Select Yes to enable output cascade module and the chainin input bus. Output cascade feature is not supported in m18x18_full operation mode.
Enable chainout port	gui_chainout_enable	No Yes	Select Yes to enable the chainout output bus. Output cascade feature is not supported in m18x18_full operation mode.



2.1.5 Pipelining Tab

Table 5. Pipelining Tab

Parameter	IP Generated Parameter	Value	Description
Add input pipeline register to the input data signal (x/y/z/coefsel)	input_pipeline_clock	No Clock0 Clock1 Clock2	Select Clock0 , Clock1 , or Clock2 to enable and specify the input clock signal for x, y, z, coefsel _a and coefsel _b pipeline input registers.
Add input pipeline register to the 'sub' data signal	sub_pipeline_clock	No Clock0 Clock1 Clock2	Select Clock0 , Clock1 , or Clock2 to enable and specify the input clock signal for the sub pipeline input register. ⁽²⁾
Add input pipeline register to the 'accumulate' data signal	accum_pipeline_clock	No Clock0 Clock1 Clock2	Select Clock0 , Clock1 , or Clock2 to enable and specify the input clock signal for the accumulate pipeline input register. ⁽²⁾
Add input pipeline register to the 'loadconst' data signal	load_const_pipeline_clock	No Clock0 Clock1 Clock2	Select Clock0 , Clock1 , or Clock2 to enable and specify the input clock signal for the loadconst pipeline input register. ⁽²⁾
Add input pipeline register to the 'negate' data signal	negate_pipeline_clock	No Clock0 Clock1 Clock2	Select Clock0 , Clock1 , or Clock2 to enable and specify the input clock signal for the negate pipeline input register. ⁽²⁾

2.1.6 Maximum Input Data Width Per Operation Mode

You can customize the data width for x, y, and z inputs as specified in the table.

⁽²⁾ All pipeline input registers for dynamic control signals must have the same clock setting.

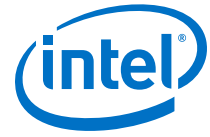
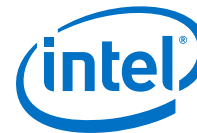

Table 6. Maximum Input Data Width Per Operation Mode

Operation Mode	Maximum Input Data Width					
	ax	ay	az	bx	by	bz
Without Pre-adder or Internal Coefficient						
m18x18_full	18 (signed)	19 (signed)	Not used	18 (signed)	19 (signed)	Not used
m18x18_sumof2	18 (unsigned)	18 (unsigned)		18 (unsigned)	18 (unsigned)	
m18x18_systolic						
m18x18_plus36						
m27x27	27 (signed) 27 (unsigned)	Not used				
With Pre-adder Feature Only						
m18x18_full	18 (signed)					
m18x18_sumof2	18 (unsigned)					
m18x18_systolic						
m27x27	27 (signed) 27 (unsigned)	26 (signed) 26 (unsigned)	Not used			
With Internal Coefficient Feature Only						
m18x18_full	Not used	19 (signed)	Not used		19 (signed)	Not used
m18x18_sumof2		18 (unsigned)			18 (unsigned)	
m18x18_systolic						
m27x27		27 (signed) 27 (unsigned)			Not used	



3 Functional Description

The Cyclone 10 GX Native Fixed Point DSP IP core consists of 2 architectures; 18×18 multiplication and 27×27 multiplication. Each instantiation of the Cyclone 10 GX Native Fixed Point DSP IP core generates only 1 of the 2 architectures depending on the selected operational modes. You can enable optional modules to your application.

Related Links

[Variable Precision DSP Blocks in Intel Cyclone 10 GX Devices chapter, Intel Cyclone 10 GX Core Fabric and General Purpose I/Os Handbook](#)

3.1 Operational Modes

The Cyclone 10 GX Native Fixed Point DSP IP core supports 5 operational modes:

- The 18×18 Full Mode
- The 18×18 Sum of 2 Mode
- The 18×18 Plus 36 Mode
- The 18×18 Systolic Mode
- The 27×27 Mode

3.1.1 The 18×18 Full Mode

When configured as 18×18 full mode, the Cyclone 10 GX Native Fixed Point DSP IP core operates as two independent 18 (signed / unsigned) \times 19 (signed) or 18 (signed / unsigned) \times 18 (unsigned) multipliers with 37-bit output. This mode applies the following equations:

- $resulta = ax * ay$
- $resultb = bx * by$



Figure 2. The 18 × 18 Full Mode Architecture

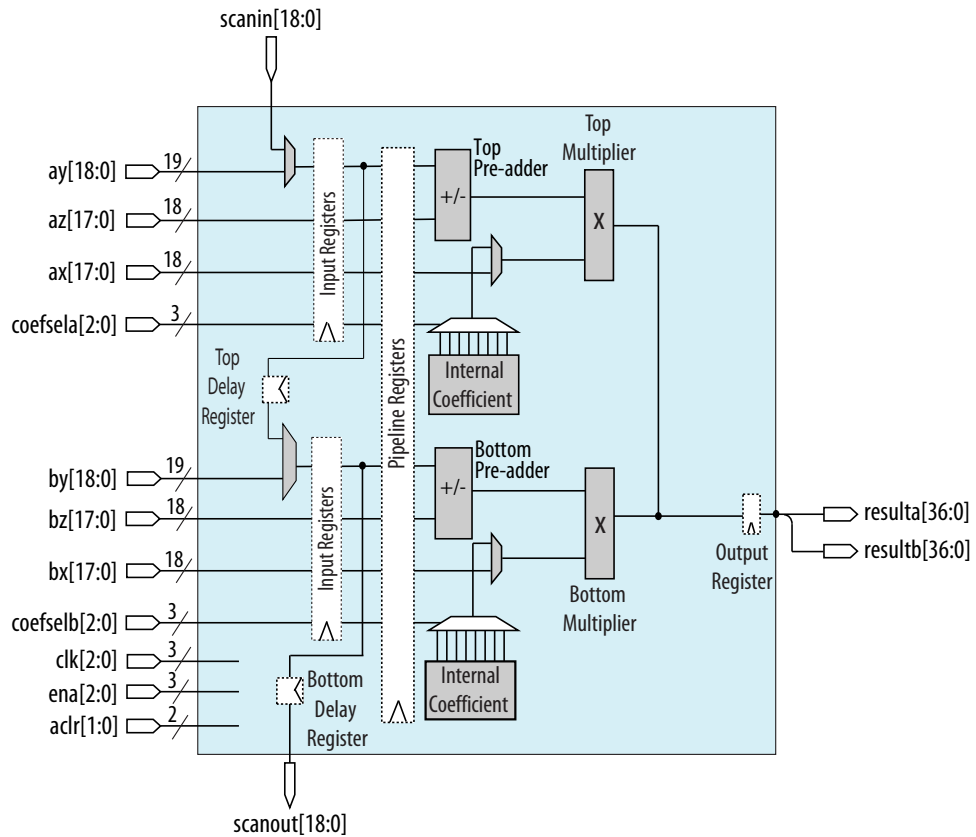

3.1.2 The 18 × 18 Sum of 2 Mode

In 18 × 18 Sum of 2 mode, the Cyclone 10 GX Native Fixed Point DSP IP core enables the top and bottom multipliers and generates a result from addition or subtraction between the 2 multipliers. The `sub` dynamic control signal controls an adder to perform the addition or subtraction operations. The `resulta` output width of the Cyclone 10 GX Native Fixed Point DSP IP core can support up to 64 bits when you enable accumulator/output cascade. This mode applies the equation of $resulta = [\pm(ax * ay) + (bx * by)]$.

Figure 3. The 18 × 18 Sum of 2 Mode Architecture

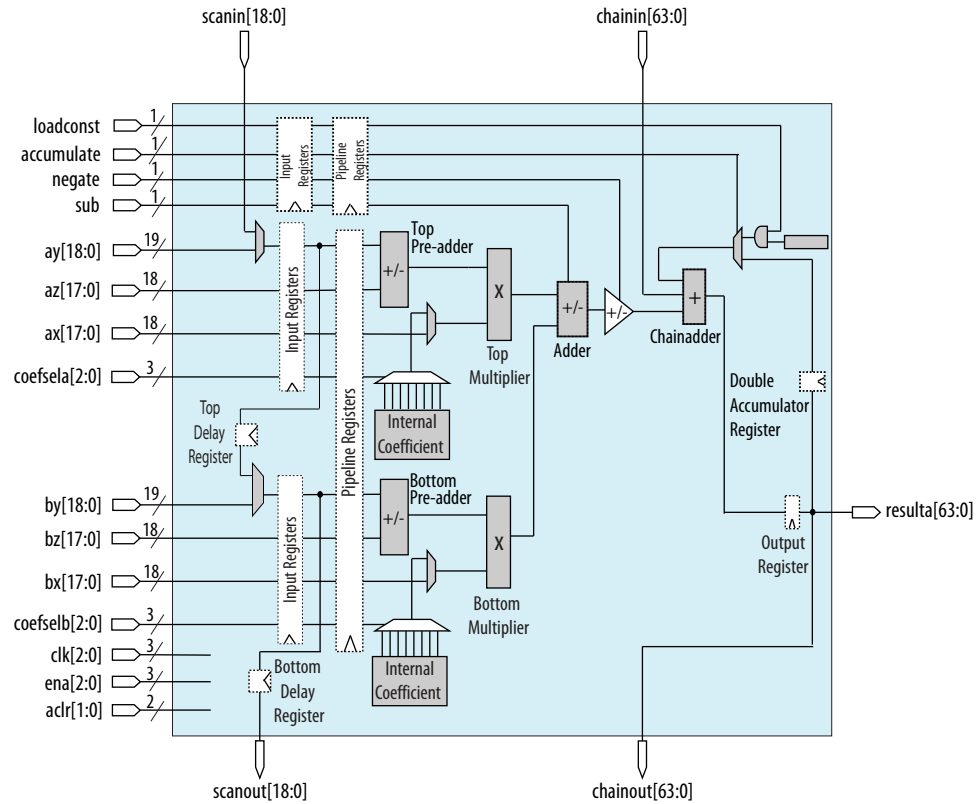

3.1.3 The 18 × 18 Plus 36 Mode

When configured as 18 × 18 Plus 36 mode, the Cyclone 10 GX Native Fixed Point DSP IP core enables only the top multiplier. This mode applies the equation of $resulta = (ax * ay) + concatenate(bx[17:0], by[17:0])$.



Figure 4. The 18 × 18 Plus 36 Mode Architecture

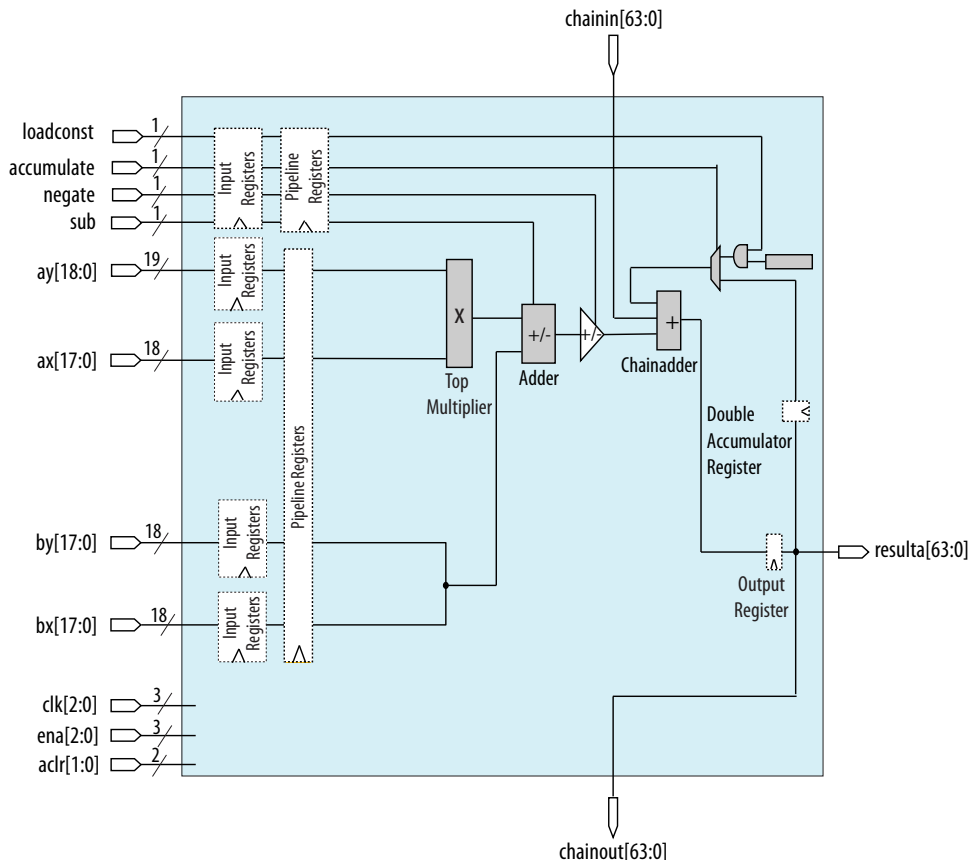

You must set **Representation format for bottom multiplier y operand** to **unsigned** when using this mode. When the input bus is less than 36-bit in this mode, you are required to provide the necessary signed extension to fill up the 36-bit input.

3.1.3.1 Using Less Than 36-bit Operand In 18 × 18 Plus 36 Mode

This example shows how to configure the Cyclone 10 GX Native Fixed Point DSP IP core to use 18 × 18 Plus 36 operational mode with a signed 12-bit input data of 1010101010 (binary) instead of a 36-bit operand.

1. Set **Representation format for bottom multiplier x operand:** to **signed**.
2. Set **Representation format for bottom multiplier y operand:** to **unsigned**.
3. Set **'bx' input bus width** to 18.
4. Set **'by' input bus width** to 18.
5. Provide data of **'1111111111111111'** to bx input bus.
6. Provide data of **'11111101010101010'** to by input bus.

3.1.4 The 18 × 18 Systolic Mode

In 18 × 18 systolic operational mode, the Cyclone 10 GX Native Fixed Point DSP IP core enables the top and bottom multipliers, an input systolic register for the top multiplier and a chainin systolic register for the chainin input signals. When you enable output cascade, this mode supports *resulta* output width of 44 bits. When you enable accumulator feature without output cascade, you can configure the *resulta* output width to 64 bits.

Figure 5. The 18 × 18 Systolic Mode Architecture

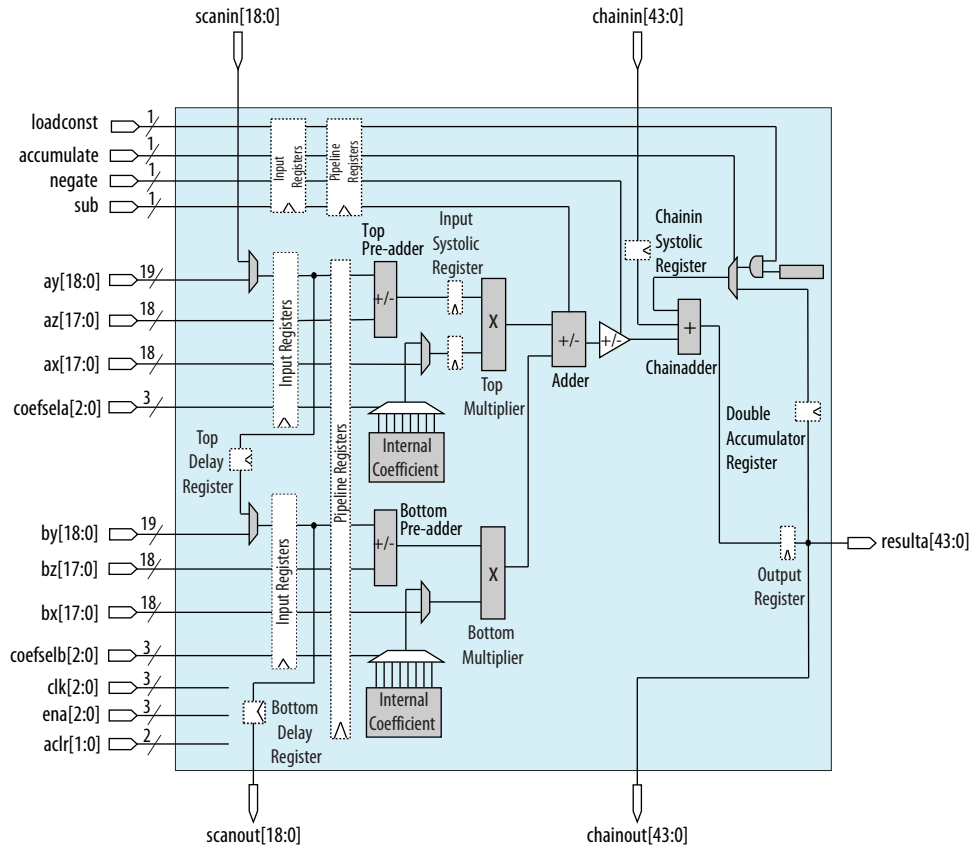

3.1.5 The 27 × 27 Mode

When configured as 27 × 27 mode, the Cyclone 10 GX Native Fixed Point DSP IP core enables a 27(signed/unsigned) × 27(signed/unsigned) multiplier. The output bus can support up to 64 bits with accumulator/output cascade enabled. This mode applies the equation of $resulta = ax * ay$.



Figure 6. The 27 × 27 Mode Architecture

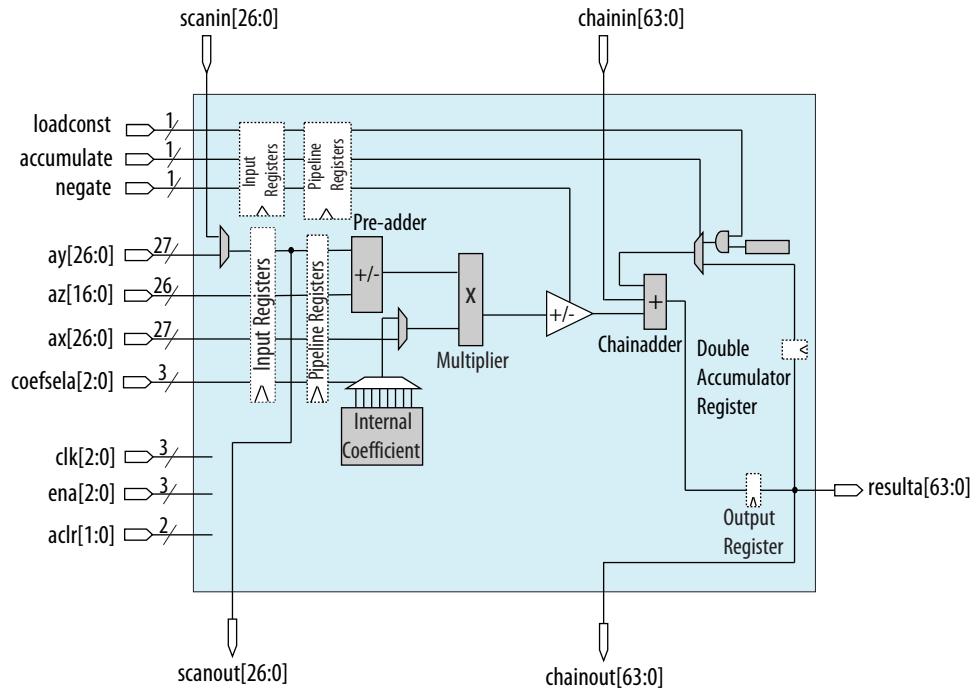

3.2 Optional Modules

The optional modules available in the Cyclone 10 GX Native Fixed Point DSP IP Core are:

- Input cascade
- Pre-adders
- Internal Coefficient
- Accumulator and output cascade
- Pipeline registers

3.2.1 Input Cascade

Input cascade feature is supported on *ay* and *by* input bus. When you set **Enable input cascade for 'ay' input** to **Yes**, the Cyclone 10 GX Native Fixed Point DSP IP core will take inputs from *scanin* input signals instead of *ay* input bus. When you set **Enable input cascade for 'by' input** to **Yes**, the Cyclone 10 GX Native Fixed Point DSP IP core will take inputs from *ay* input bus instead of *by* input bus.

It is recommended to enable the input registers for *ay* and/or *by* whenever input cascade is enabled for correctness of application.



You can enable the delay registers to match the latency requirement between the input register and the output register. There are 2 delay registers in the core. The top delay register is used for `ay` or `scanin` input ports while the bottom delay register is used for `scanout` output ports. These delay registers are supported in 18×18 full mode, 18×18 sum of 2 mode, and 18×18 systolic mode.

3.2.2 Pre-adder

The pre-adder can be configured in the following configurations:

- Two independent 18-bit (signed/unsigned) pre-adders.
- One 26-bit pre-adder.

When you enable pre-adder in 18×18 multiplication modes, `ay` and `az` are used as the input bus to the top pre-adder while `by` and `bz` are used as the input bus to the bottom pre-adder. When you enable pre-adder in 27×27 multiplication mode, `ay` and `az` are used as the input bus to the pre-adder.

The pre-adder supports both addition and subtraction operations. When both pre-adders within the same DSP block are used, they must share the same operation type (either addition or subtraction).

3.2.3 Internal Coefficient

The internal coefficient can support up to eight constant coefficients for the multiplicands in 18-bit and 27-bit modes. When you enable the internal coefficient feature, two input bus to control the selection of the coefficient multiplexer will be generated. The `coefsela` input bus is used to select the predefined coefficients for top multiplier and `cofselb` input bus is used to select the predefined coefficients for bottom multiplier.

The internal coefficient storage does not support dynamically controllable coefficient values and external coefficient storage is required to perform such operation.

3.2.4 Accumulator and Output Cascade

The accumulator module can be enabled to perform the following operations:

- Addition or subtraction operation
- Biased rounding operation using a constant value of 2^N
- Dual channel accumulation

To dynamically perform addition or subtraction operation of the accumulator, control the `negate` input signal.

For biased rounding operation, you can specify and load a preset constant of 2^N before the accumulator module is enabled by specifying an integer to the parameter **N value of preset constant**. The integer N must be less than 64. You can dynamically enable or disable the use of the preset constant by controlling the `loadconst` signal. You can use this operation as an active muxing of the round value into the accumulator feedback path. The `loadconst` and the `accumulate` signals usage is mutually exclusive.



You can enable the double accumulator register using the parameter **Enable double accumulator** to perform double accumulation.

The accumulator module can support chaining of multiple DSP blocks for addition or subtraction operation by enabling `chainin` input port and `chainout` output port. In 18×18 systolic mode, only 44-bit of the `chainin` input bus and `chainout` output bus will be used. However, all 64-bit `chainin` input bus must be connected to the `chainout` output bus from the preceding DSP block.

3.2.5 Pipeline Register

The Cyclone 10 GX Native Fixed Point DSP IP core supports a single level of pipeline register. The pipeline register supports up to three clock sources and one asynchronous clear signal to reset the pipeline registers. There are five pipeline registers:

- data input bus pipeline register
- sub dynamic control signal pipeline register
- negate dynamic control signal pipeline register
- accumulate dynamic control signal pipeline register
- loadconst dynamic control pipeline register

You can choose to enable each data input bus pipeline registers and the dynamic control signal pipeline registers independently. However, all enabled pipeline registers must use the same clock source.

3.3 Clocking Scheme

The input, pipeline, and output registers in the Cyclone 10 GX Native Fixed Point DSP IP core supports three clock sources/enables and two asynchronous clears. All input registers use `aclr[0]` and all pipeline and output registers use `aclr[1]`. Each register type can select one of the three clock sources and clock enable signals.

When you configure the Cyclone 10 GX Native Fixed Point DSP IP core to 18×18 systolic operation mode, the Intel Quartus Prime software will set the input systolic register and the `chainin` systolic register clock source to the same clock source as the output register internally.

When you enable the double accumulator feature, the Intel Quartus Prime software will set the double accumulator register clock source to the same clock source as the output register internally.

Table 7. Clocking Scheme Constraints

This table shows the constraints you must apply for all the registers clocking scheme.

Condition	Constraint
When pre-adder is enabled	Clock source for <code>ay</code> and <code>az</code> input registers must be the same.
<i>continued...</i>	

Condition	Constraint
	Clock source for by and bz input registers must be the same.
When pipeline registers are enabled	Clock source for all pipeline registers must be the same.
When any of the input registers for dynamic control signals	Clock source for input registers for sub, accumulate, loadconst, and negate must be the same.

3.4 Cyclone 10 GX Native Fixed Point DSP IP Core Signals

The following figure shows the input and output signals of the Cyclone 10 GX Native Fixed Point DSP IP core.

Figure 7. Cyclone 10 GX Native Fixed Point DSP IP Core Signals

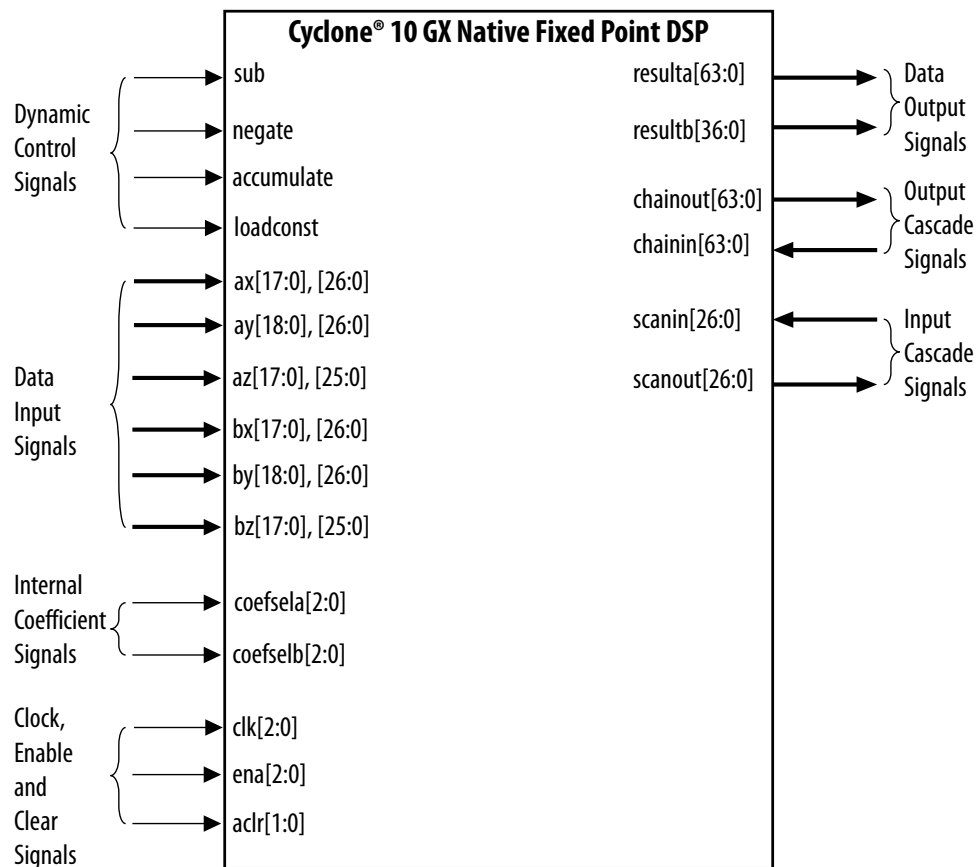

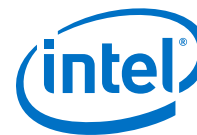

Table 8. Data Input Signals

Signal Name	Type	Width	Description
ax[]	Input	27	Input data bus to top multiplier.
ay[]	Input	27	Input data bus to top multiplier. When pre-adder is enabled, these signals are served as input signals to the top pre-adder.
az[]	Input	26	These signals are input signals to the top pre-adder. These signals are only available when pre-adder is enabled. These signals are not available in m18x18_plus36 operational mode.
bx[]	Input	18	Input data bus to bottom multiplier. These signals are not available in m27x27 operational mode.
by[]	Input	19	Input data bus to bottom multiplier. When pre-adder is enabled, these signals serve as input signals to the bottom pre-adder. These signals are not available in m27x27 operational mode.
bz[]	Input	18	These signals are input signals to the bottom pre-adder. These signals are only available when pre-adder is enabled. These signals are not available in m27x27 and m18x18_plus36 operational modes.

Table 9. Data Output Signals

Signal Name	Type	Width	Description
resulta[]	Output	64	Output data bus from top multiplier. These signals support up to 37 bits for m18x18_full operational mode.
resultb[]	Output	37	Output data bus from bottom multiplier. These signals only available in m18x18_full operational mode.

Table 10. Clock, Enable, and Clear Signals

Signal Name	Type	Width	Description
clk[]	Input	3	Input clock signals for all registers. These clock signals are only available if any of the input registers, pipeline registers, or output register is set to Clock0 , Clock1 , or Clock2 . <ul style="list-style-type: none"> • clk[0] = Clock0 • clk[1] = Clock1 • clk[2] = Clock2
ena[]	Input	3	Clock enable for clk[2:0]. This signal is active-High. <ul style="list-style-type: none"> • ena[0] is for Clock0 • ena[1] is for Clock1 • ena[2] is for Clock2
aclr[]	Input	2	Asynchronous clear input signals for all registers. This signal is active-High. Use aclr[0] for all input registers and use aclr[1] for all pipeline registers and output register. By default, this signal is de-asserted.

Table 11. Dynamic Control Signals

Signal Name	Type	Width	Description
sub	Input	1	Input signal to add or subtract the output of the top multiplier with the output of the bottom multiplier. <ul style="list-style-type: none"> Deassert this signal to specify addition operation. Assert this signal to specify subtraction operation. By default, this signal is deasserted. You can assert or deassert this signal during run-time. ⁽³⁾
negate	Input	1	Input signal to add or subtract the sum of top and bottom multipliers with the data from chainin signals. <ul style="list-style-type: none"> Deassert this signal to specify addition operation. Assert this signal to specify subtraction operation. By default, this signal is deasserted. You can assert or deassert this signal during run-time. ⁽³⁾
accumulate	Input	1	Input signal to enable or disable the accumulator feature. <ul style="list-style-type: none"> Deassert this signal to disable the accumulator feature. Assert this signal to enable the accumulator feature. By default, this signal is deasserted. You can assert or deassert this signal during run-time. ⁽³⁾
loadconst	Input	1	Input signal to enable or disable the load constant feature. <ul style="list-style-type: none"> Deassert this signal to disable the load constant feature. Assert this signal to enable the load constant feature. By default, this signal is deasserted. You can assert or deassert this signal during run-time. ⁽³⁾

Table 12. Internal Coefficient Signals

Signal Name	Type	Width	Description
coefsela[]	Input	3	Input selection signals for 8 coefficient values defined by user for the top multiplier. The coefficient values are stored in the internal memory and specified by parameters coef_a_0 to coef_a_7 . <ul style="list-style-type: none"> coefsela[2:0] = 000 refers to coef_a_0 coefsela[2:0] = 001 refers to coef_a_1 coefsela[2:0] = 010 refers to coef_a_2 ... and so forth. These signals are only available when the internal coefficient feature is enabled.
cofselb[]	Input	3	Input selection signals for 8 coefficient values defined by user for the bottom multiplier. The coefficient values are stored in the internal memory and specified by parameters coef_b_0 to coef_b_7 . <ul style="list-style-type: none"> cofselb[2:0] = 000 refers to coef_b_0 cofselb[2:0] = 001 refers to coef_b_1 cofselb[2:0] = 010 refers to coef_b_2 ... and so forth. These signals are only available when the internal coefficient feature is enabled.

⁽³⁾ Do not tie this signal to 0 when the input register or the pipeline register is enabled.



Table 13. Input Cascade Signals

Signal Name	Type	Width	Description
scanin[]	Input	27	Input data bus for input cascade module. Connect these signals to the scanout signals from the preceding DSP core.
scanout[]	Output	27	Output data bus of the input cascade module. Connect these signals to the scanin signals of the next DSP core.

Table 14. Output Cascade Signals

Signal Name	Type	Width	Description
chainin[]	Input	64	Input data bus for output cascade module. Connect these signals to the chainout signals from the preceding DSP core.
chainout[]	Output	64	Output data bus of the output cascade module. Connect these signals to the chainin signals of the next DSP core.



A Document Revision History for the Cyclone 10 GX Native Fixed Point DSP IP Core User Guide

Date	Version	Changes
November 2017	2017.11.06	Initial release.

Intel Corporation. All rights reserved. Intel, the Intel logo, Altera, Arria, Cyclone, Enpirion, MAX, Nios, Quartus and Stratix words and logos are trademarks of Intel Corporation or its subsidiaries in the U.S. and/or other countries. Intel warrants performance of its FPGA and semiconductor products to current specifications in accordance with Intel's standard warranty, but reserves the right to make changes to any products and services at any time without notice. Intel assumes no responsibility or liability arising out of the application or use of any information, product, or service described herein except as expressly agreed to in writing by Intel. Intel customers are advised to obtain the latest version of device specifications before relying on any published information and before placing orders for products or services.

*Other names and brands may be claimed as the property of others.

**ISO
9001:2008
Registered**